

## SOLAR PANEL

MONOCRYSTALLINE SOLAR PANEL FOR BEANDEVICE® WILLOW® POWER SUPPLY  
( COMPATIBLE WITH -EHR POWER EXTENSION ONLY )

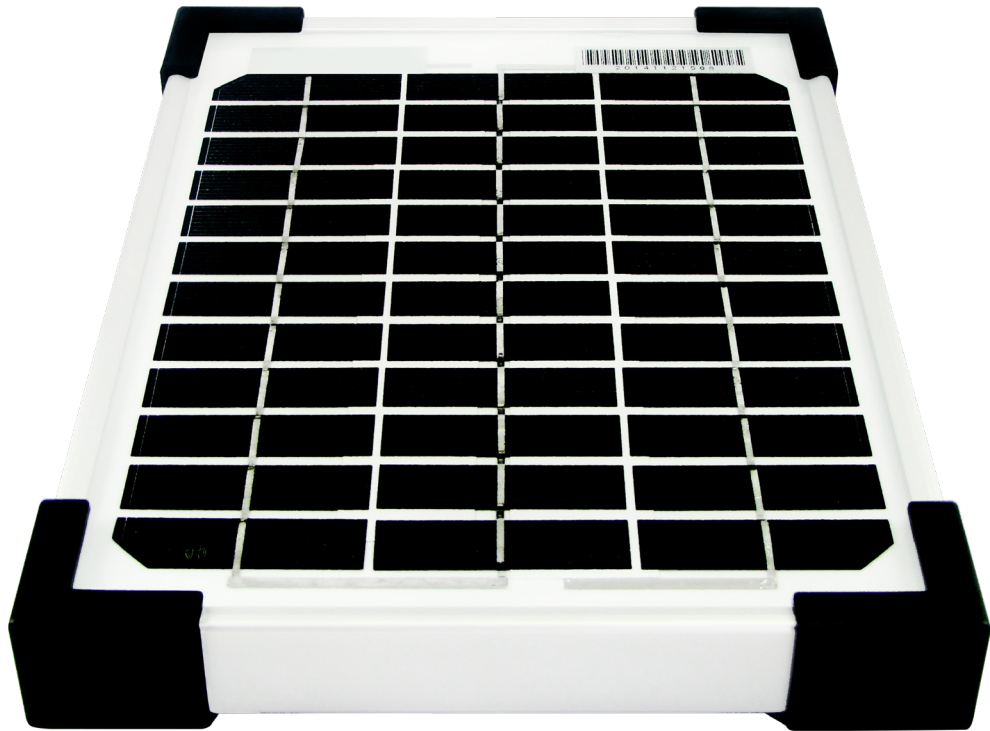

**REF : WL-SLP-5W**

For BeanDevice® Wilow® with the extension -EHR Only  
(auxiliary power supply 6-24 VDC compatible with Energy Harvesting)

**SOLAR PANEL**

**SOLAR PANEL CHARACTERISTICS**

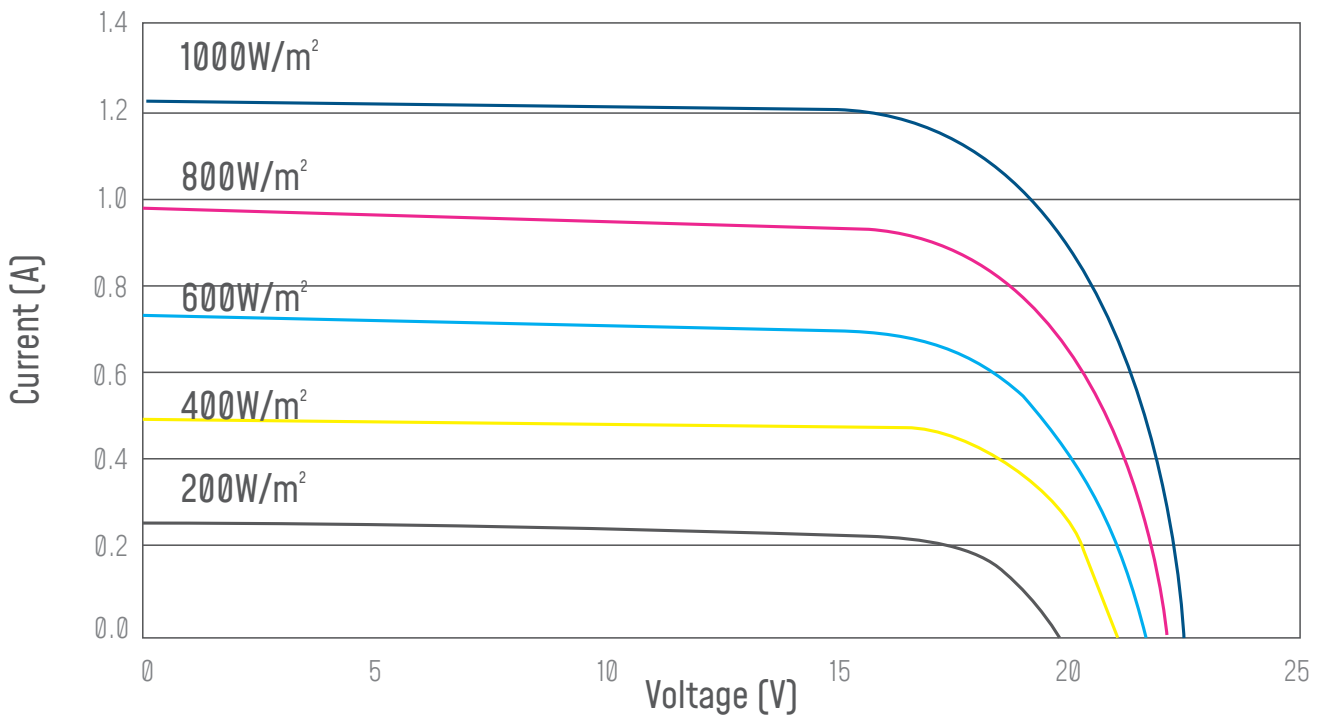
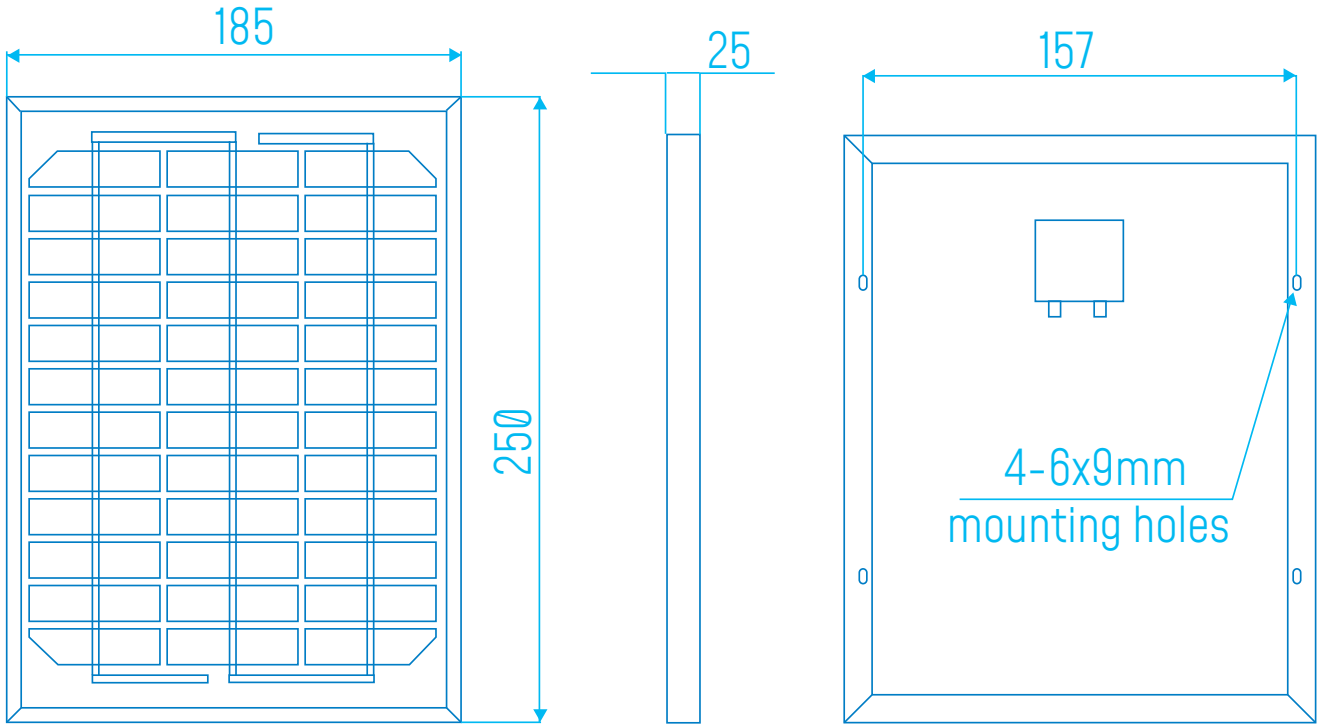

## SOLAR PANEL

### TECHNICAL SPECIFICATIONS

#### MONOCRYSTALLINE SOLAR PANEL FOR BEANDEVICE® WILLOW® POWER SUPPLY ( COMPATIBLE WITH -EHR POWER EXTENSION ONLY )

Maximum Power	5W
Optimum operating Voltage	12 VDC
Max Voltage	17.8V
Max Current	0.28A
Efficiency	16%
Operating Temperature	-40°C to +85°C
Temperature Coeff.	-0.45%/°C
Dimensions	250 x 185 x 25 mm
Weight	0.7kg
Protection Frame	Aluminum Frame , Waterproof IP67
Cable Length	2 meters REF: WL-SLP-5W-2M or 5 meters REF: WL-SLP-5W-2M with M8-6 Pins plug for a direct to connection to the BeanDevice® Wilow®
Can work with the following Data Acquisition mode	Low Duty Cycle, Alarm, Streaming with Burst Data Acquisition Mode with battery saver mode enabled

### CONTACT US

#### Headquarter:

BeanAir GmbH  
Wolfener Straße 32 - 34  
12681 Berlin

#### Email:

info@beanair.com

#### Phone number:

+49 30 98366680



[www.facebook.com/BeanAir](http://www.facebook.com/BeanAir)



[www.beanair.com](http://www.beanair.com)



[www.youtube.com/user/BeanairSensors](http://www.youtube.com/user/BeanairSensors)



[www.twitter.com/beanair](http://www.twitter.com/beanair)

