

BeanAir X-SOLAR 14H

HIGH EFFICIENCY SOLAR PANEL WITH SOLAR CHARGING CONTROLLER AND LEAD-ACID BATTERY

FEATURED VIDEO



USER GUIDE



TECHNICAL NOTE



MECHANICAL DRAWING



MADE IN GERMANY

2year
Warranty

CE FC

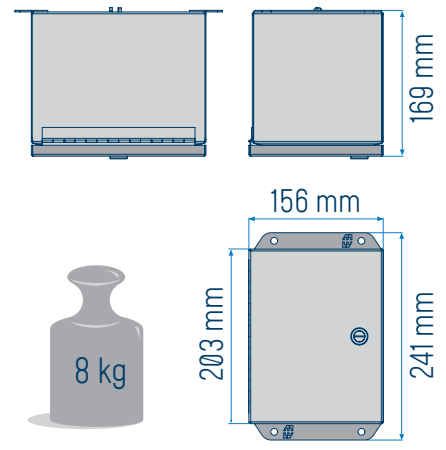

SOLAR PANEL



X-SOLAR



TECHNICAL SPECIFICATIONS

PRODUCT REFERENCE

X-SOL-14AH-SLP-VOUT-CL

SLP- Solar Panel Power	CL- Cable length between X-solar box and solar panel
20W (adapted to countries with very High level of solar Irradiance : Africa / South Asia / South America)	5M : 5 METERS
50W (adapted to countries with High level of solar Irradiance : South of Europe / South USA)	
100W (adapted to countries with Low level of solar Irradiance : North Europe / North USA /Canada / North Asia / Russia)	
VOUT - Voltage Output	
4VDC : 4 channels with 4VDC output	
5VDC : 4 channels with 12VDC output (only for Willow sensor series)	
12VDC : 4 channels with 12VDC output	
Example: X-SOL-14AH-20W-4CH-4V-5M, 20W Solar panel, 4VDC output and 5 meters cable	

SOLAR PANEL SPECIFICATIONS

Maximum Power (Pmax)	High efficiency Monocrystalline solar cell technology
Max Energy efficiency	20.4%
Maximum Power (Pmax)	20W, 50W or 100W
Voltage at Pmax	17.8VDC
Current at Pmax	1.12A(20W), 2.8A(50W), 4.5A(100W)
Operating Temperature	-40°C to +85°C
Dimensions and Weight (20W version)	345 x 370 x 25, 2 kg weight
Dimensions and Weight (50W version)	662 x 460 x 35mm, 4 kg weight
Dimensions and Weight (80W version)	810 x 700 x 35mm, 7.8kg weight
Connector Type	M12-4pins Male , A-Coding
IP Rating	Waterproof IP67 NEMA 6
Cable length	5 meters
Mounting method	Screw mounting

TECHNICAL SPECIFICATIONS

INCLUDED CONNECTORS

For 2.4GHz sensor series	8 x M8-3Pins Plugs for connecting to your X-SOLAR to your BeanDevice® 2.4GHz
For Wilow® sensor series	4x M8-3Pins Plugs for connecting your X-SOLAR to your BeanDevice® Wilow® 1 x M8-3Pins Plugs for connecting your X-SOLAR to your BeanDevice® Wilow® Wilow® sensors comes with M8-6Pins socket, you can only use a M8-6Pin molded cable to connect it to your X-SOLAR

OPTIONAL CABLE ADAPTERS

For 2.4GHz sensor series	Molded Cable M8-3 pins to M8-3Pins for X-Solar Box Only, PVC Material 2.4GHZ-XSOLAR-CBL-2M for 2 meters of cable length 2.4GHZ-XSOLAR-CBL-5M for 5 meters of cable length 2.4GHZ-XSOLAR-CBL-10M for 10 meters of cable length
For Wilow® sensor series	Molded Cable M8-6 pins to M8-3Pins for X-Solar Box Only, PVC Material WL-XSOLAR-CBL-2M for 2 meters of cable length WL-XSOLAR-CBL-5M for 5 meters of cable length WL-XSOLAR-CBL-10M for 10 meters of cable length
M12 Plug to build your own power supply	M12-4Pins Plug to build your own power supply (screw mounting) Ref: XSOLAR-M12-4PIN
M8 Plug For Xsolar connection	M8-3Pins Plug for connecting X-SOLAR Box (screw mounting) Ref: XSOLAR-M8-3P
AC/DC power adapter	AC/DC power adapter to load the X-SOLAR battery at your office Ref: XSOLAR-AC-DC-PWR-12VDC

BeanAir X-SOLAR 14H

CHARGING CONTROLLER BOX SPECIFICATIONS

Charging controller type	Solar charging controller with Overvoltage/Undervoltage protection
Input voltage solar cell panel	14-30VDC
Connector Types	4 x M8-3Pins Female A-Coding for sensors power 1 x M12-4Pins Female A-Coding for Solar panel
Number of output voltage	4
Output Voltage	4VDC (only for 2.4GHz sensor series with XT option) 12VDC (only for 2.4GHz sensor series) 5VDC (only for Willow sensor series)
Max Input current	10A
Power consumption	< 10mA , Led switch on
Battery Technology	Valve regulated lead acid battery
Battery Capacity	14Ah
Led displays	Battery Full and Charging
Dimensions	204 mm x169 mm x 156 mm
IP Rating	Waterproof IP67 NEMA 6
Weight	8 kg
Operating Temperature	-15°C to +50°C

LIST OF BEANDEVICE® COMPATIBLE WITH X-SOLAR [4VDC]

All the Beandevicé® coming with -XT extension Example: BND-2.4GHZ-HI-INC-15B-XT, BND-2.4GHZ-INC-30B-XT

LIST OF BEANDEVICE® COMPATIBLE WITH X-SOLAR [5VDC]

All the Beandevicé® Willow® Example: BND-WILOW-AX-3D-2G , BND-WILOW-AX-3D-10G,
BND-WILOW-HI-INC-15B, BND-WILOW-X-INC-2G-15B

LIST OF BEANDEVICE® COMPATIBLE WITH X-SOLAR [12VDC]

All the Beandevicé® 2.4Ghz coming with internal Rechargeable battery , and all the BeanDevicé Willow with EHR Option Example: BND-2.4GHZ-AX3D-10G-RB, BND-2.4GHZ-HI-INC-15B-XR-RB-SCM

PRODUCT OVERVIEW



X-Solar

SOLAR PANEL CHARACTERISTICS

X-SOL-14AH-20W-4CH-4V-5M or X-SOL-14AH-20W-4CH-12V-5M

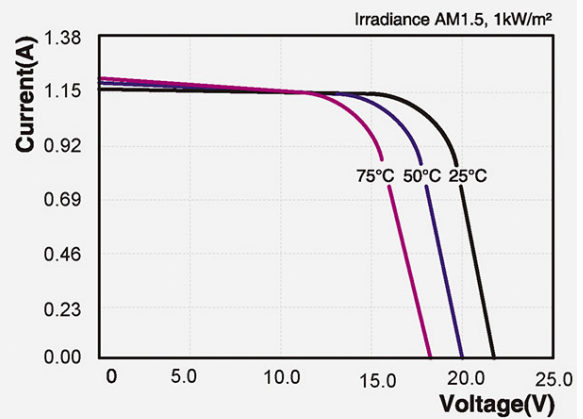
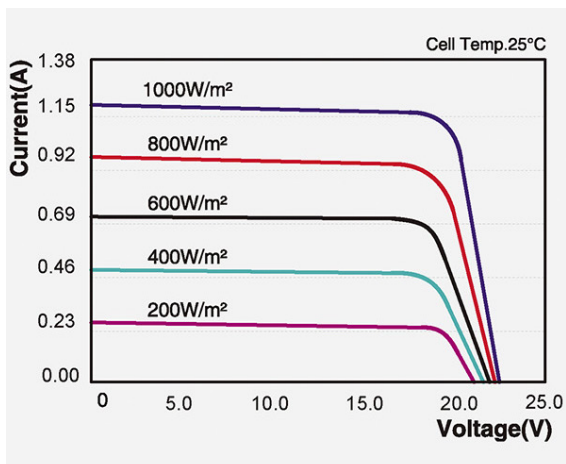
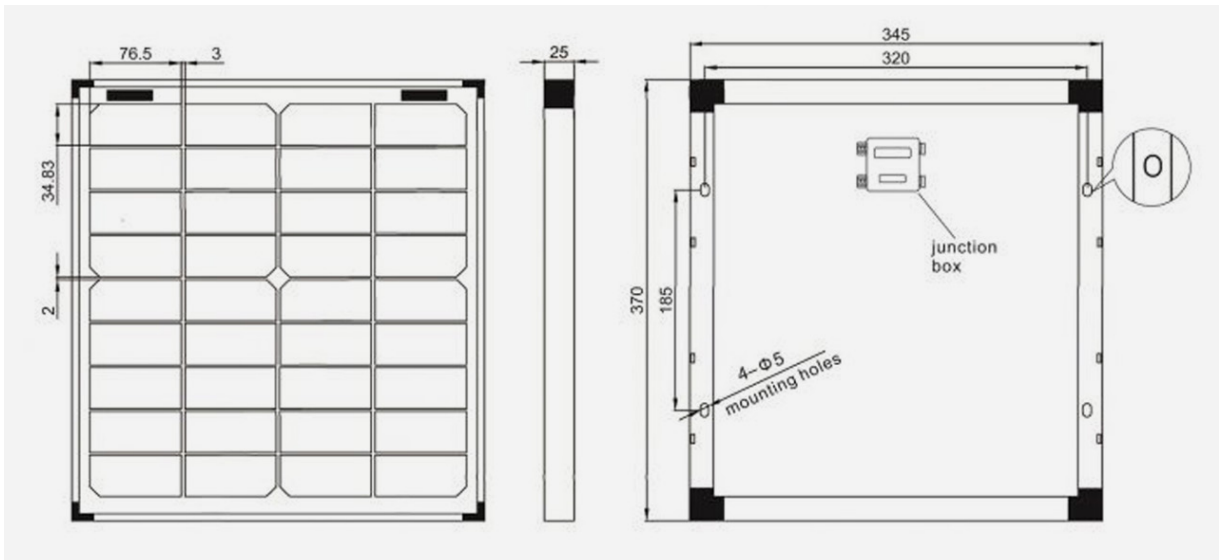

X-SOL-14AH-50W-4CH-4V-5M or X-SOL-14AH-50W-4CH-12V-5M

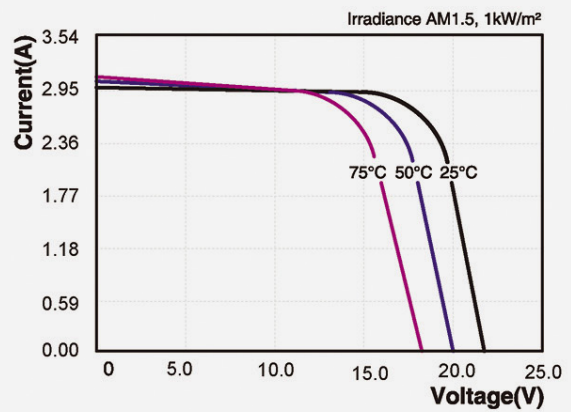
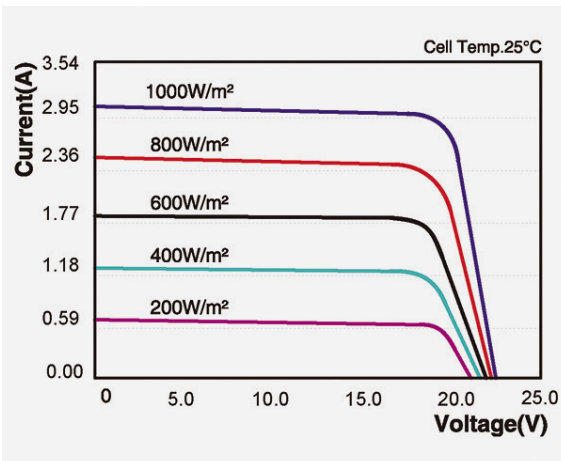
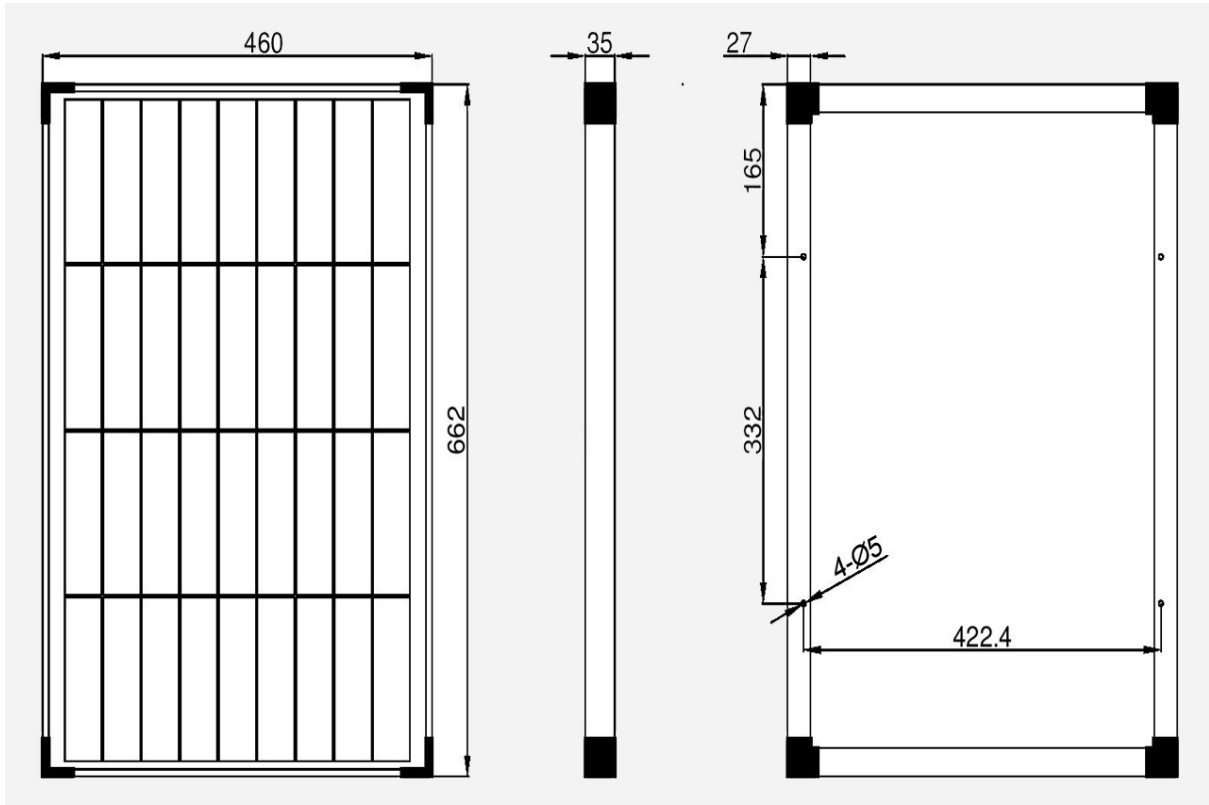

X-SOL-14AH-100W-4CH-4V-5M or X-SOL-14AH-100W-4CH-12V-5M

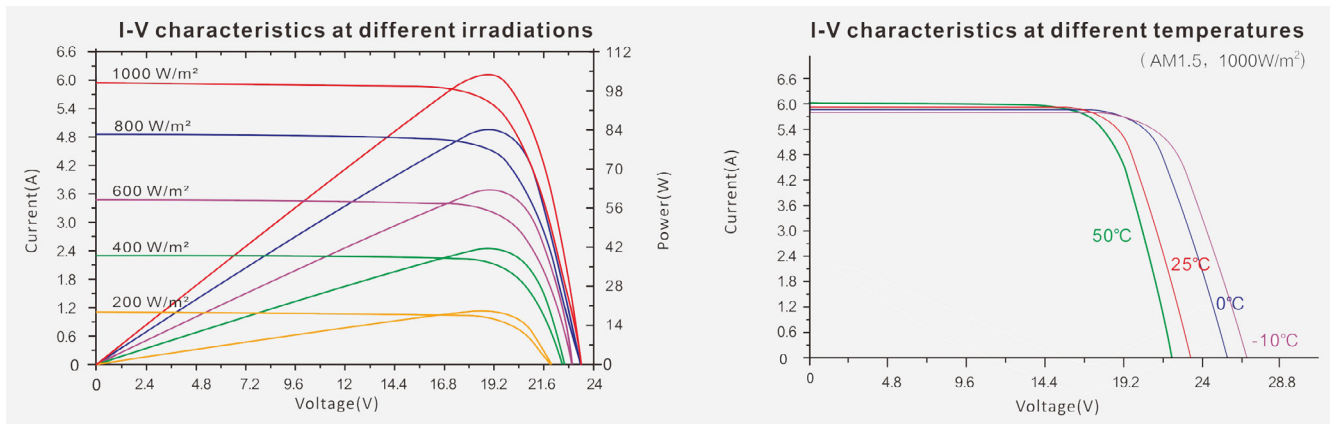
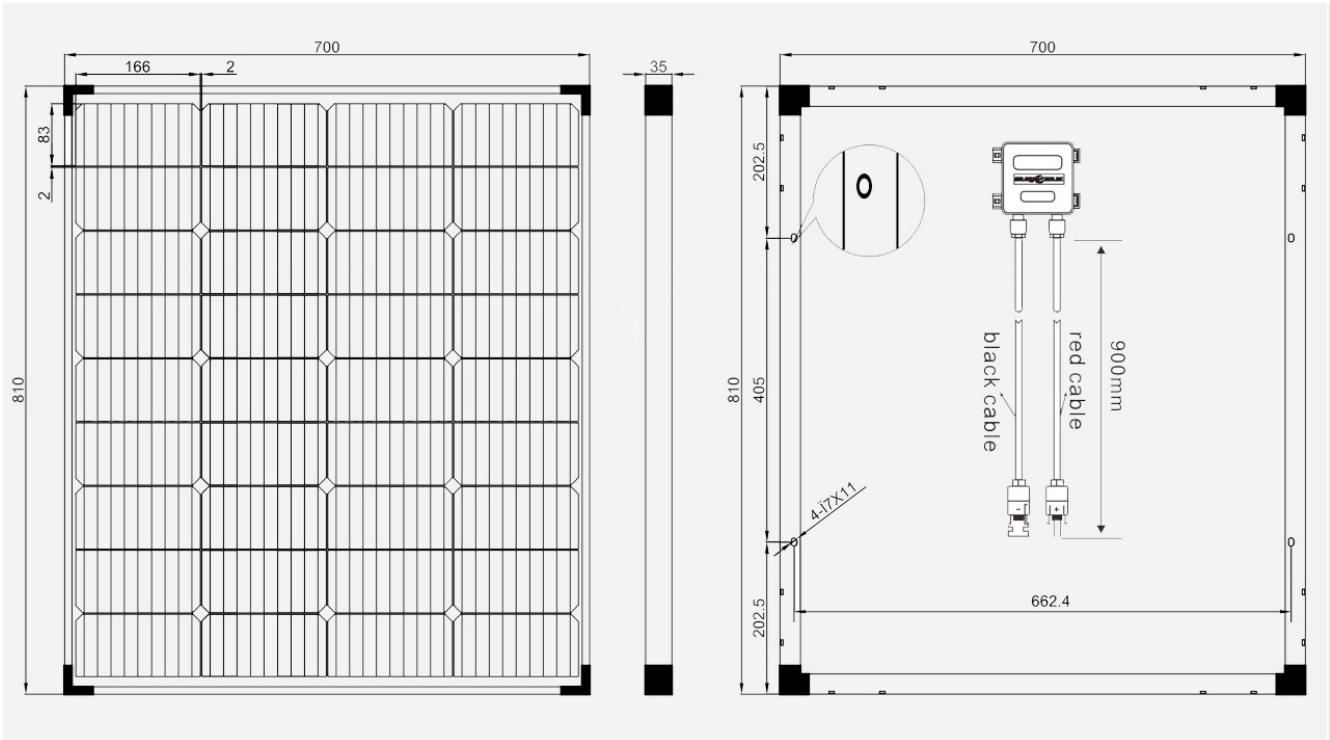

BeanAir X-SOLAR 14H

CONTACT US

Headquarter:

Email:

Phone number:

BeanAir GmbH
Wolfener Straße 32 - 34
12681 Berlin

info@beanair.com

+49 30 98366680



www.facebook.com/BeanAir



www.beanair.com



www.youtube.com/user/BeanairSensors



www.twitter.com/beanair

