

BeanDevice® 2.4GHz AX-3DS

Wireless IIOT accelerometer sensor | Shock and impact monitoring

PRODUCT VIDEO



SmartSensor



2 year
Warranty

MADE IN GERMANY



001A-08148

FEATURED VIDEO



USER GUIDE



QUICK START



MECHANICAL DRAWING



STEP FILE



155g

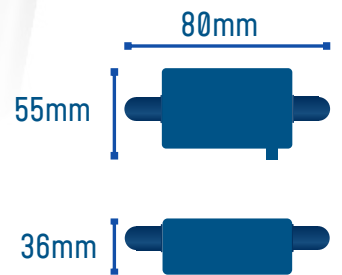

MAIN FEATURES



• Embedded data logger : up to 1 million data points (with events dating)



• Excellent radio link relying on the radio antenna diversity developed by Beanair®



• Wireless accelerometer dedicated to shock
Scalable measurement range :
±6g/±12g/±24g or ±2g/±4g/±8g



• SSD (Smart Shock Detection), wireless sensor can wakeup on shock detection (software configurable)



• Waterproof IP67 casing (Nema 6)



• Integrated Lithium-Ion battery charger

BeanDevice® 2.4GHz AX-3DS

APPLICATIONS

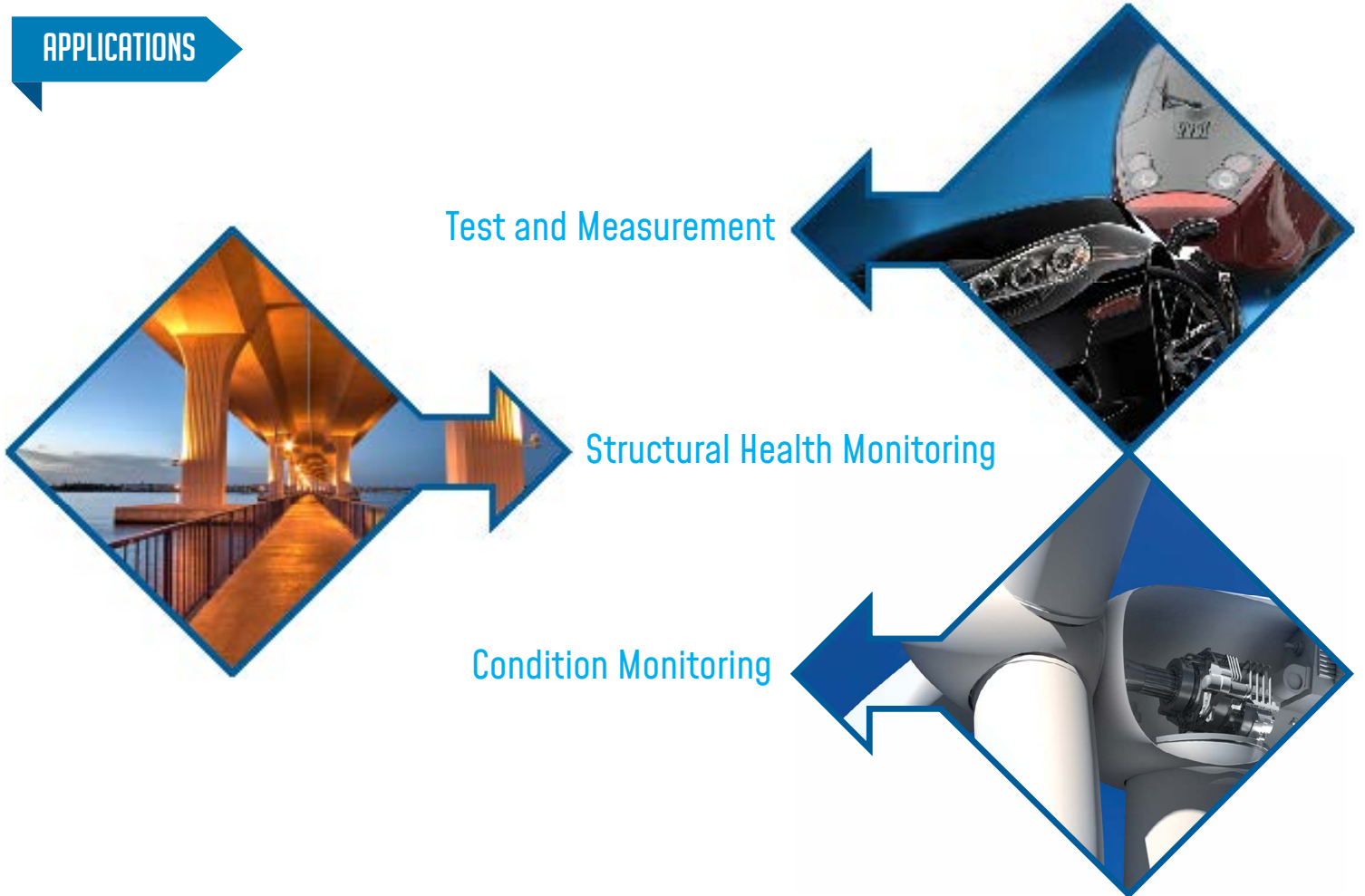

SMART SHOCK DETECTION TECHNOLOGY



The [BeanDevice® 2.4GHz AX-3DS](#) integrates a smart shock detection technology which permits to detect & recognize a shock event during the sleeping or deep sleeping mode of the [BeanDevice® 2.4GHz AX-3DS](#). When the [BeanDevice® 2.4GHz AX-3DS](#) is in sleeping mode, the accelerometer continues to track a shock event with a power consumption of 68 uA in sleeping mode and 28uA in deep sleeping mode. A hysteresis on the shock event, fully configurable through the [BeanScape® 2.4GHz](#), allows to avoid false alarm.

EXAMPLE : THIS CURVE SHOWS TWO SHOCK EVENTS, ONE CONSIDERED AS SIGNIFICANT (REAL ALARM) AND ANOTHER CONSIDERED AS NOT SIGNIFICANT (FALSE ALARM).

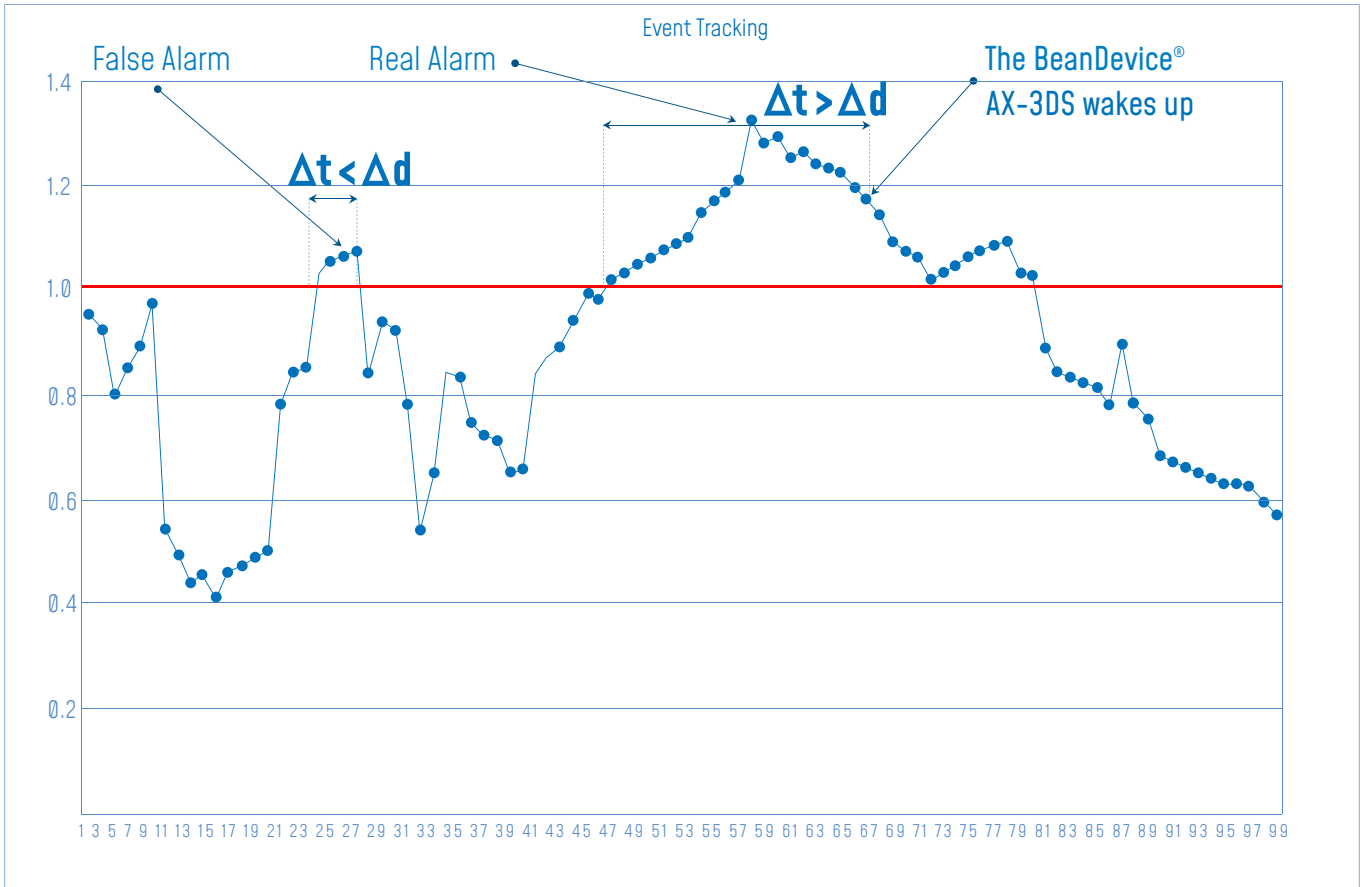

Δd : shock detection hysteresis.

Δt : Observed duration

If $\Delta t = \Delta d$, the shock event is detected and recognized, the BeanDevice® wakes up and start data sampling in “streaming mode”.

The following tables show the accelerometer sampling rate and the hysteresis time value in deep sleeping mode and sleeping mode of the BeanDevice® 2.4GHz AX-3DS.

Accelerometer sampling rate during deep sleeping mode (in HZ)	Δd max value(s)	Resolution
0.5	128 s	2 s
1	64 s	1 s
2	32 s	500 ms
5	12.8 s	200 ms
10	6.4 s	100 ms

Accelerometer sampling rate during deep sleeping mode (in HZ)	Δd max value(s)	Resolution
50	1.28 s	20 ms
100	640 ms	10 ms
400	160 ms	2.5 ms
1000	64 ms	1 ms

BeanDevice® 2.4GHz AX-3DS

SHOCK MEASUREMENT ON PANTOGRAPH



Wireless IOT Sensors
Supervision Software



Ethernet LAN Interface



BeanGateway® 2.4GHz

Wireless IOT Sensors coordinator
Outdoor Version



BeanDevice®
2.4GHz AX-3DS

REMOTE CONFIGURATION & MONITORING

BeanScope® 2.4GHz Basic

The [BeanScope® 2.4GHz application](#) allows the user to view all the data transmitted by the [BeanDevice® 2.4 GHz AX-3DS](#) With the OTAC (Over-the-Air configuration) feature.

SEVERAL DATA ACQUISITION MODES ARE AVAILABLE ON THE BEANDEVICE® 2.4 GHz AX-3DS :

- **Low Duty Cycle Data Acquisition mode (LDCDA)** : the data acquisition is immediately transmitted by radio. The transmission frequency can be configured from 1s to 24h.
- **Survey Mode**: the measured value is transmitted by radio whenever an alarm threshold (fixed by the user) is detected (4 alarms threshold levels High/Low). Meanwhile, the device sends frequently a beacon frame informing its current status.
- **Streaming Packet Mode** : all measured values are transmitted by packet within a continuous flow at 3 kpsps/s maximum

BeanDevice® 2.4GHz AX-3DS

REMOTE CONFIGURATION & MONITORING



For further information about the different data acquisition modes:
TN-RF-008 – “Data acquisition modes available on the BeanDevice®”

ANTENNA DIVERSITY

While the vast majority of wireless IIOT sensors show their limits in harsh industrial environment, the BeanDevice® 2.4GHz AX-3DS integrates an innovative antenna diversity design, boosting the radio link quality in environments subject to random and diverse disturbances. Antenna Diversity improves both the quality and reliability of a wireless link by 30%.



EMBEDDED DATA LOGGER UP TO 1 MILLION DATA POINTS

The BeanDevice® 2.4GHz AX-3DS integrates an embedded data logger, which can be used to log data when a wireless IIOT sensors can not be easily deployed on your site. All the data acquisition are stored on the embedded flash and then transmitted to the BeanGateway® 2.4 GHz when a wireless IIOT sensors is established.

The data logger function is compatible with all the data acquisition mode available on your BeanDevice® 2.4 GHz AX-3DS :

- LowDutyCycle Data Acquisition
- Survey
- Shock detection
- Streaming packet

BeanDevice® 2.4GHz AX-3DS

EXAMPLE : SHOCK DETECTION ON A TRAIN



- In standalone operation, the BeanDevice® 2.4GHz AX-3DS stores all the measurements on its embedded datalogger. Thus, a direct connection with the BeanGateway® 2.4GHz is not needed.
- When the train is moving, all the acquired measurements are stored on datalogger.
- Data logs can be transmitted to the BeanGateway® 2.4GHz on request. Once a successful transmission is done, the user can choose to erase automatically the logs from the datalogger memory, so new ones can be stored.



For further information about the Datalogger, please read the following technical note :
TN-RF-007 – “BeanDevice® DataLogger User Guide ”

TECHNICAL SPECIFICATIONS

PRODUCT REFERENCE

BND-2.4GHZ-AX3DS -MR-RB-MO

MR – Measurement Range (1g = 9806.65 mm/s²)
24G : ±6/12/24g measurement range
8G : ±2/4/8g measurement range

PS - Power Supply
RB : Rechargeable battery

MO - Mounting Option
SCM - Screw Mounting Lid
MM - Magnetic Mounting Lid
Leave it empty if there is no mounting option

Example 1: BND-2.4GHZ-AX3DS-24G-RB, Wireless Accelerometer with ±6/12/24g measurement range, rechargeable battery
Example 2: BND-2.4GHZ-AX3DS-8G-RB-SCM, Wireless Accelerometer with ±2/4/8g measurement range, rechargeable battery, screw mounting option

TECHNICAL SPECIFICATIONS

SENSOR SPECIFICATIONS

Accelerometer Technology	Low power MEMS technology
Scalable measurement range	24G Version : $\pm 6g / \pm 12g / \pm 24g$ 8G Version : $\pm 2g / \pm 4g / \pm 8g$
Measurement resolution	24G Version : 3 mg/digit @ $\pm 6g$, 6 mg/digit @ $\pm 12g$, 12 mg/digit @ $\pm 24g$ 8G Version : 1mg/digit @ $\pm 2g$, 2 mg/digit @ $\pm 4g$, 3.9 mg/digit @ $\pm 8g$
Typical non-linearity (Full scale, @ 25°C)	$\pm 0.09\%$ for the version BND-2.4GHZ-AX3DS-8G-RB $\pm 0.11\%$ for the version BND-2.4GHZ-AX3DS-24G-RB
Sensitivity change Vs temperature	$\pm 0.01\% / ^\circ C$
Zero-g level change vs temperature (max delta from 25°C)	24G Version : $\pm 0.4 \text{ mg}/^\circ C$ 8G Version : $\pm 0.1 \text{ mg}/^\circ C$
Typical zero-g level offset accuracy	24G Version : $\pm 70 \text{ mg}$ 8G Version : $\pm 20 \text{ mg}$
Analog to Digital converter	12-bit with temperature compensation
Noise spectral density @ BW 10Hz	24G Version : $250 \mu g/\sqrt{Hz}$ 8G Version : $118 \mu g/\sqrt{Hz}$
Anti-aliasing filter	Butterworth 2th order filter

CONFIGURABLE SETTINGS FROM THE BEANSCAPE® 2.4GHZ SOFTWARE

Data Acquisition mode (SPS = sample per second)	Dynamic data acquisition: Streaming and SSD (Smart Shock Detection)
Shock detection function	<ul style="list-style-type: none"> Shock threshold in mg Data acquisition sample rate in sleeping mode Data acquisition sample rate after the shock detection Shock detection hysteresis
Sampling Rate (in streaming mode)	Minimum: 1 SPS Maximum: 3 kSPS per axis (one axis enabled) 1.5 kSPS per axis (2-axis enabled) 1 kSPS per axis (3-axis enabled)
Power Mode	Battery saver mode & Active power mode

EMBEDDED DATA LOGGER

Storage capacity	up to 1 millions data points
Wireless data downloading	3 minutes to download the full memory (average time)

TIMESYNC FUNCTION : CLOCK SYNCHRONIZATION OVER THE WIRELESS IOT SENSOR

Clock synchronization accuracy	$\pm 2.5 \text{ ms}$ (at 25°C)
Crystal specifications	Tolerance $\pm 10\text{ppm}$, stability $\pm 10\text{ppm}$

BeanDevice® 2.4GHz AX-3DS

TECHNICAL SPECIFICATIONS

RF SPECIFICATIONS

Wireless Technology	Ultra-Power and license-free 2.4Ghz radio technology (IEEE 802.15.4E)
WSN Topology	Point-to-Point / Star
Data rate	250 Kbits/s
RF Characteristics	ISM 2.4GHz – 16 Channels. Antenna diversity designed by Beanair®
TX Power	+18 dBm
Receiver Sensitivity	-104dBm
Maximum Radio Range	500 m in Line-Of-Sight 30-100 m in Non-Line-of-Sight
Antenna	Omnidirectional radome antenna with antenna diversity Gain : 3 dBi Waterproof IP67

ENVIRONMENTAL AND MECHANICAL

Casing	Aluminum AL6061 & Waterproof casing Dimensions in mm (LxWxH): 80x55x36 mm Weight (battery included) : 155g
IP NEMA Rating	IP67 Nema 6
Shock resistance	100g during 50 ms
Operating Temperature	-40 °C to +60 °C
Norms	<ul style="list-style-type: none"> · CE Labelling Directive R&TTE (Radio) ETSI EN 300 328 · FCC (North America) · ARIB STD-T66 Ver 3.6 ROHS - Directive 2002/95/EC

POWER SUPPLY

Integrated battery charger	Integrated Lithium-ion battery charger with high precision battery monitoring : <ul style="list-style-type: none"> • Overvoltage/Overcurrent/Short-Circuit/Undervoltage protection • Battery Temperature monitoring
Current consumption @3,3V	<ul style="list-style-type: none"> • During data acquisition : 20 to 30 mA • During Radio transmission : 60 mA @ 18 dBm • During sleeping mode: 68uA • During Battery Saver Mode : < 28 µA
External power supply	8-28VDC with reverse polarity protection
Rechargeable Lithium-Polymer battery	Capacity 1.25 Ah

INCLUDED ACCESSORIES

	1x Magnet to Power ON/Power OFF the device
	1x M8 Cap for Power Supply

BeanDevice® 2.4GHz AX-3DS

TECHNICAL SPECIFICATIONS

OPTIONAL ACCESSORIES AND SERVICES

External Power Supply

Wall plug-in, Switchmode power Supply 12V @ 1.25A with sealed M8 Plug (IP67/Nema 6)
Ref: [M8-PWR-12V](#)

M8 extension cable for external power supply

Molded cable with M8-3pins male plug
Material: PVC with shield protection
IP Rating : IP67 | Nema 6
Cable length: 2 meters , Ref : [CBL-M8-2M](#)
Cable length : 5 meters, Ref : [CBL-M8-5M](#)
Cable length: 10 meters, Ref : [CBL-M8-10M](#)

Calibration certificate

Calibration certificate provided by Beanair GmbH
A static calibration method is used on a granite surface plate DIN876 Ref: [CERT-CAL-SMART](#)

GETTING STARTED WITH A WIRELESS IIOT SENSORS

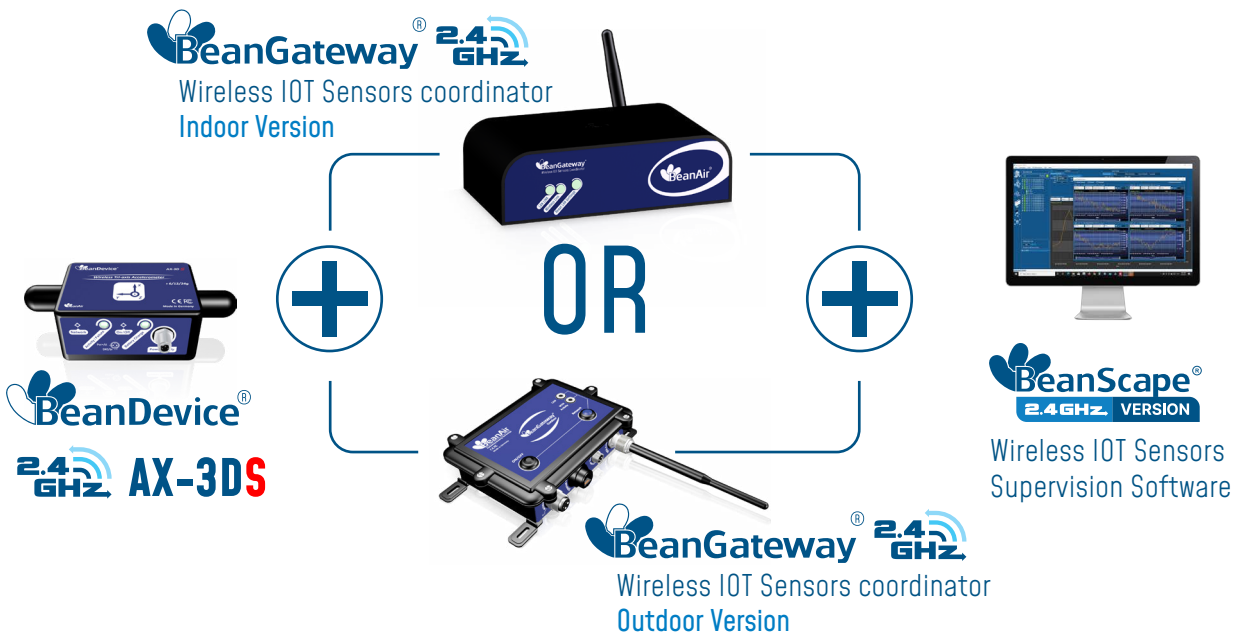

The **BeanDevice® 2.4 GHz AX-3DS** operates only on our wireless IIOT sensors, you will need the **BeanGateway® 2.4GHz** and the **BeanScope® 2.4GHz** for starting a wireless IIOT sensors



For further information about BeanDevice® battery life :
TN-RF-002 Current consumption in active & sleeping mode
TN-RF-012 Beandevic autonomy in Streaming and Streaming Packet Mode

BeanDevice® 2.4GHz AX-3DS

BEANDEVICE® 2.4GHz AX-3DS FRONT VIEW



Product specifications are subject to change without notice.
Contact Beanair for latest specifications.

EXTERNAL POWER SUPPLY WIRING CODE

M8 Socket (A-Coding) - Pin Assignment

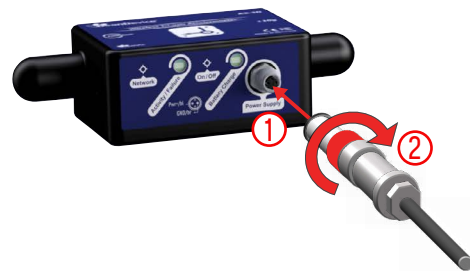
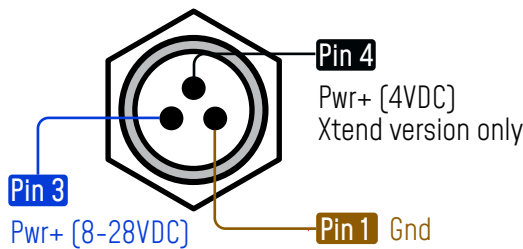

Interface Name	M8 Pin assignment	Wire Color [A-coding]
Power Supply 8-28VDC	PIN 3	Blue
Power Supply 4VDC [available on Xtend version only]	PIN 4	Black
Ground	PIN 1	Brown

M8 Plug (A -Coding) - Pin Assigantion

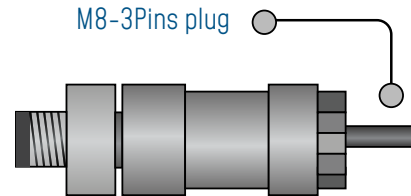
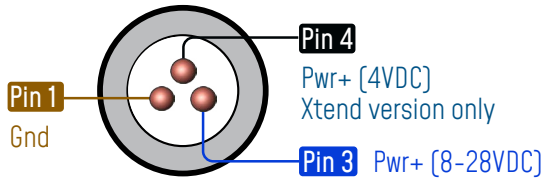

Do not power PIN4 and PIN3 at the same time, you will damage your Beandevicce

OPTIONS AND ACCESSORIES

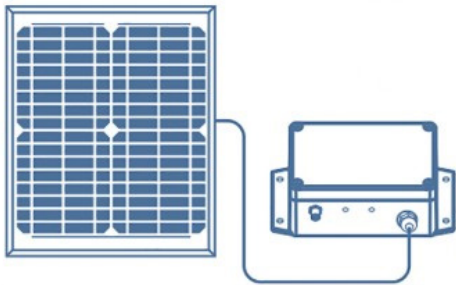

Solar Panel Kit

High efficiency solar panel with solar charging controller and Lead-acid battery
Ref: X-SOL-SLP-VOUT-CL

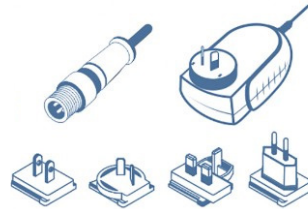

External Power-Supply

Wall plug-in, Switchmode power Supply 12V @ 1,25A with sealed M8 Plug (IP67/Nema 6)
Ref: M8-PWR-12V

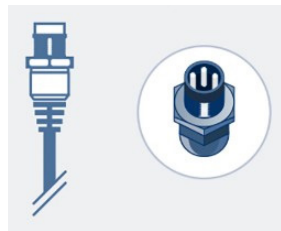

M8 extension cable for external power supply

Molded cable with M8-3pins male plug
Material: PVC with shield protection
IP Rating : IP67 | Nema 6
Cable length: 2 meters , Ref: CBL-M8-2M
Cable length : 5 meters, Ref: CBL-M8-5M
Cable length: 10 meters, Ref: CBL-M8-10M

BeanDevice® 2.4GHz AX-3DS

DRAWING

“No screw mounting option, this device should be glue mounted or use a **tape/cable-tie**”

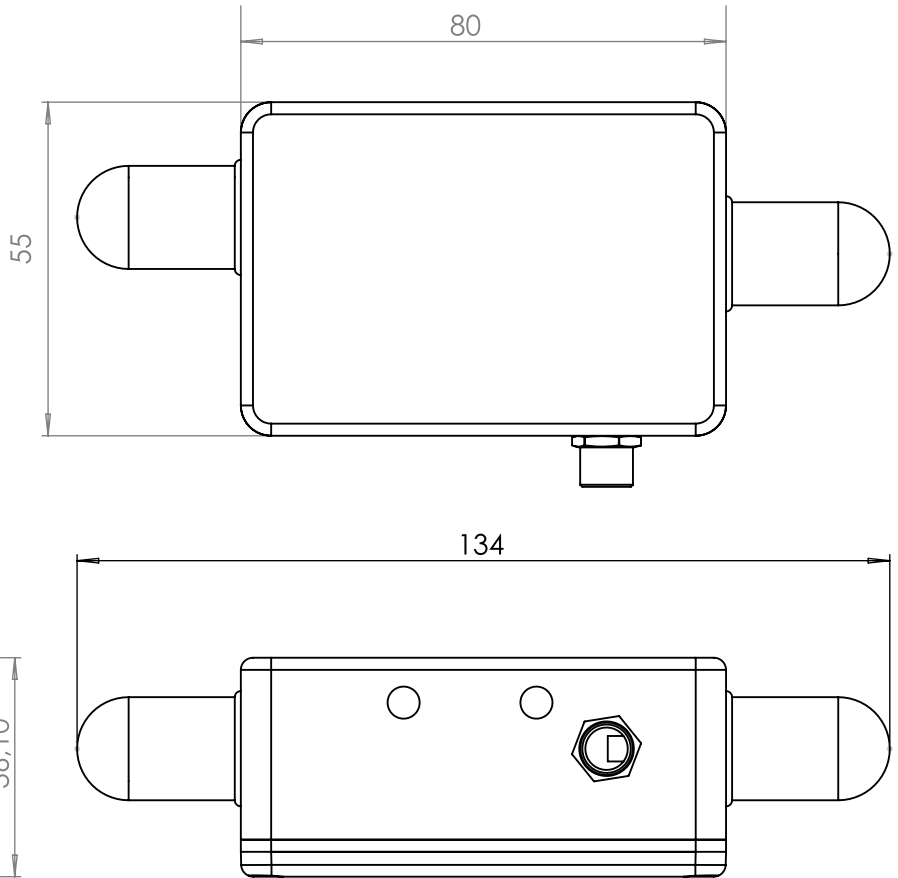

CONTACT US

Headquarter:

Buchholzer Straße 65, 13156
Berlin, Germany

Email:

info@beanair.com

Phone number:

+493066405051



www.industrial-wsn.com



WWW.BEANAIR.COM



www.youtube.com/user/BeanairSensors



www.facebook.com/BeanAir

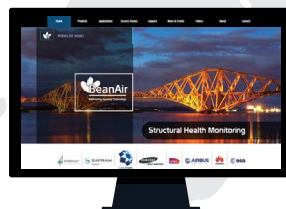

www.twitter.com/beanair

